

SOLOMIX STATIONARY

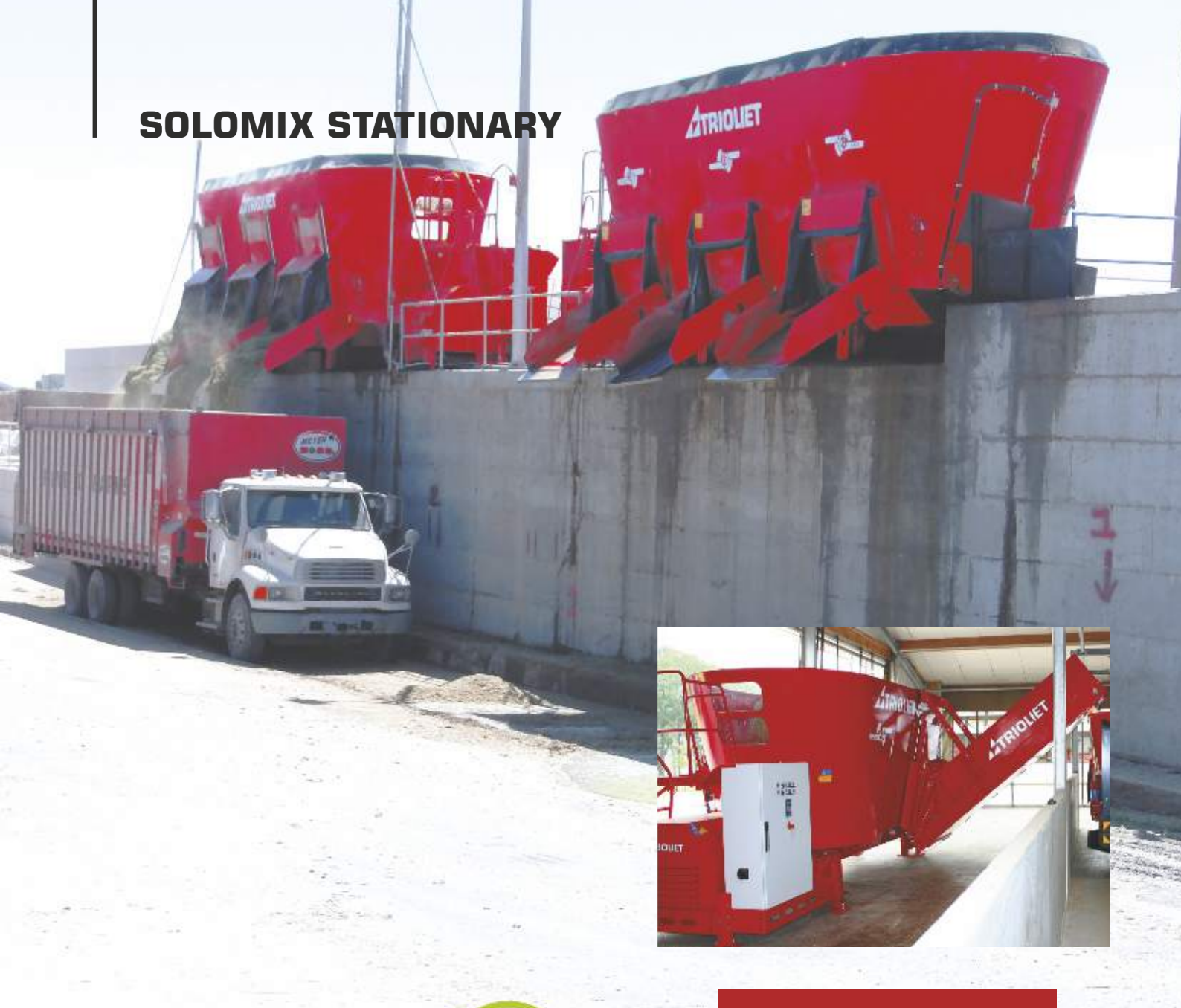

STATIONARY MIXER FEEDERS

Range 700-5200

Trioliet. Invests for you.

 **TRIOLIET**
FEEDING TECHNOLOGY

Trioliet feeding technology | since 1950

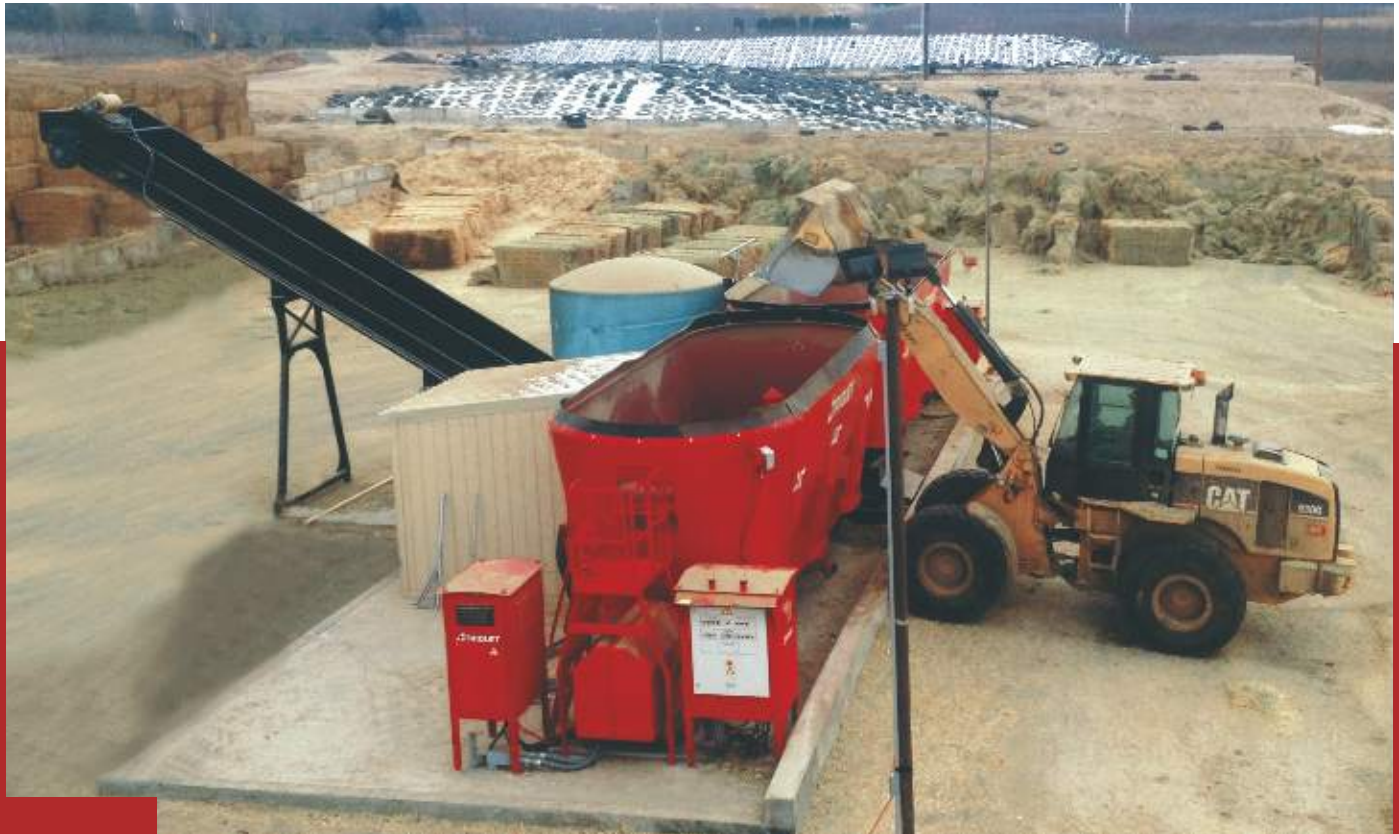

Trioliet. Invents for you!

Trioliet is a leading Dutch company engaged in the development, production and marketing of machines and systems for feeding dairy and beef at modern, professional farms. This position is based on over 65 years of experience in (silage) feeding technology. Listening to the wishes and requirements of the dairy and beef farmer enables us to offer made-to-measure solutions, anywhere in the world. Not surprising therefore, that today Trioliet exports well over 80% of its machines to more than 50 countries worldwide. Machines for silagecutting, loading, mixing and feeding.



Trioliet Green Label

Trioliet regards sustainability as of the highest importance. We want to contribute to a better environment for both people and animals. The population of the world is increasing, with a growing demand for dairy products, so it is ever more important that we should be conscious of our environment. We have patented a number of inventions that make our machines not only safer and more user-friendly, but also durable and economical.

Over 65 years of innovation



Trioliet head office, Oldenzaal, the Netherlands

Stationary feed mixing systems	4
Plug & Play systems	5
Unique features	6
Heavy Duty (HD) systems	9
Control systems	10
Triotronic weighing systems	12
Trioliet Feed management systems	13
Accessoires	15
Chain conveyors	16
Technical Specifications	18

Trioliet stationary feed mixing systems



Easy & Smart

The Solomix Stationary line comprises stationary units, which can be perfectly integrated into complete feed kitchens. The Solomix Stationary line is based on easy and smart operation, accurate weighing, economical operation and long life.

Unique features on the Solomix Stationary line are:

- Consistent TMR from start to finish, regardless of tub size
- Twin stream mixing augers for rapid mixing without compromising feed quality
- Accurate scale system
- Fast discharge with superior cleanout because of rounded side doors
- Smart design engineered with few moving parts for long life, low maintenance and trouble free operation
- Control system. Both manual control units and automatic control systems are available for controlling loading, weighing, mixing and unloading.
- Heavy Duty Drive Line with heavy duty planetary gearboxes (no reduction gearboxes)
- Preprogrammed frequency drive with unique software for automatic mixing speed control during mixing cycle.
- Horizontal Flow by offset inserts for optimal and quick mixing in both vertical and horizontal direction.
- Suitable stationary mixers for every farm.
- Capacity: 7 to 52 m³/250 to 1,860 cu.ft

Configuration of a stationary feed mixing system

Configuration of stationary feeding systems up to 150 HP (110kW)

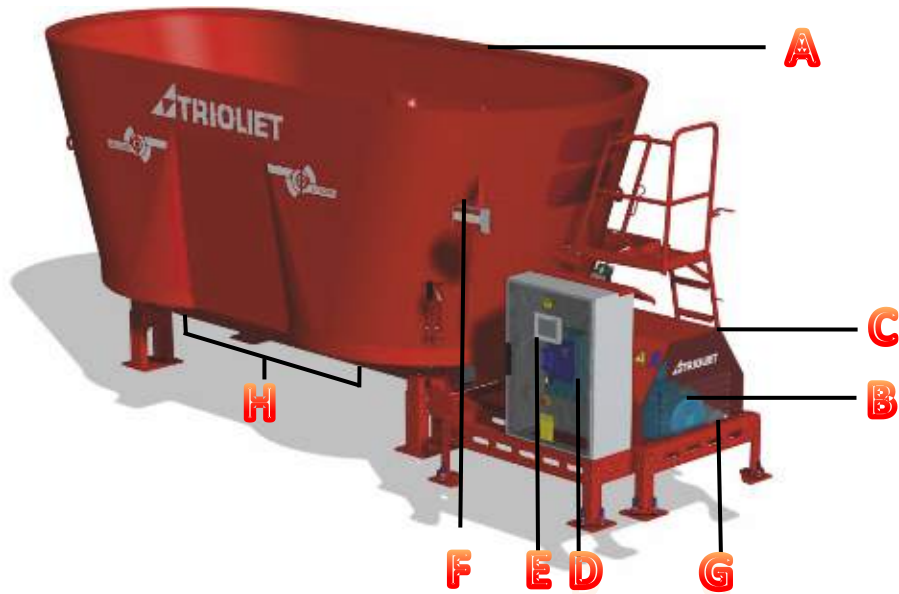

Configuration of stationary Heavy Duty (HD) feeding systems from 150 HP (110kW) onwards

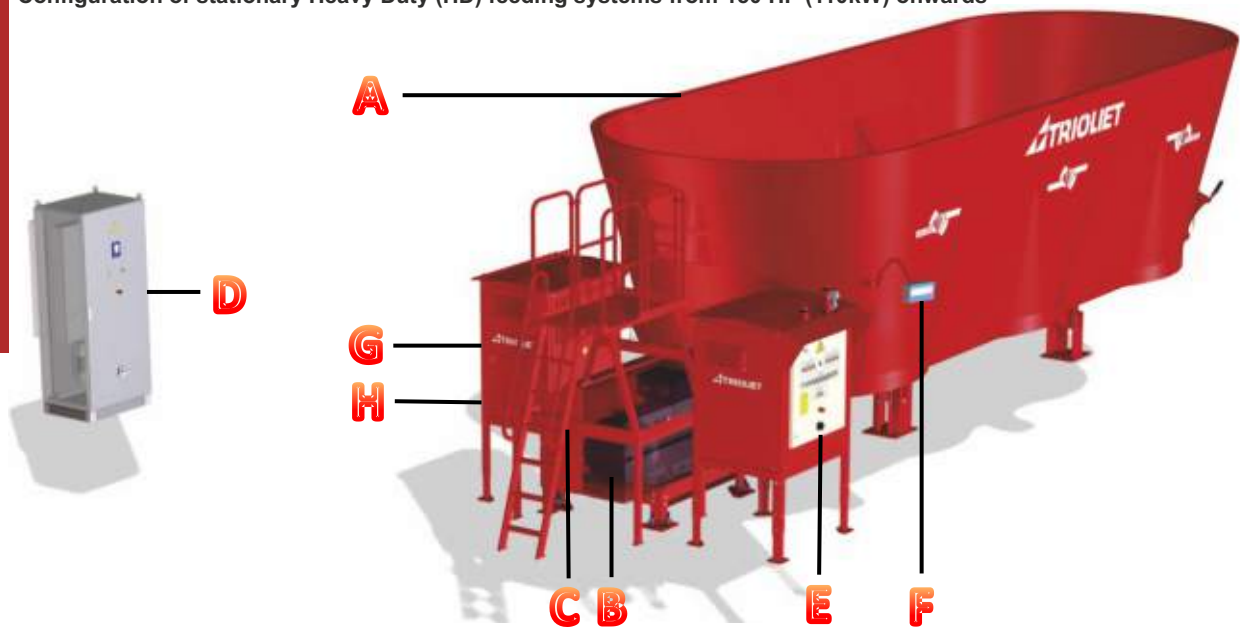

Plug & Play systems.

Trioliet is the only manufacturer of stationary feed mixing systems who delivers Plug & Play systems in which all components are integrated.

A stationary feed mixing system consists of several building groups:

- Group A** Stationary mixer incl. adjustable supports and discharge door with protection
- Group B** Electric motors
- Group C** Motor frame kits
- Group D** Frequency drives
- Group E** Control systems
- Group F** Weighing systems
- Group G** Hydraulic pump kits
- Group H** Cooling systems

Unique features on the Solomix Stationary line

Unique bearing construction

The auger bearings include a maintenance-free conical roller bearing at the top and a sinter sleeve bearing at the bottom. This bearing construction will absorb all axial and radial auger forces. The large bearing distance ensures maximum stability.

Control system. Both manual control units and automatic control systems are available for controlling loading, weighing, mixing and unloading.

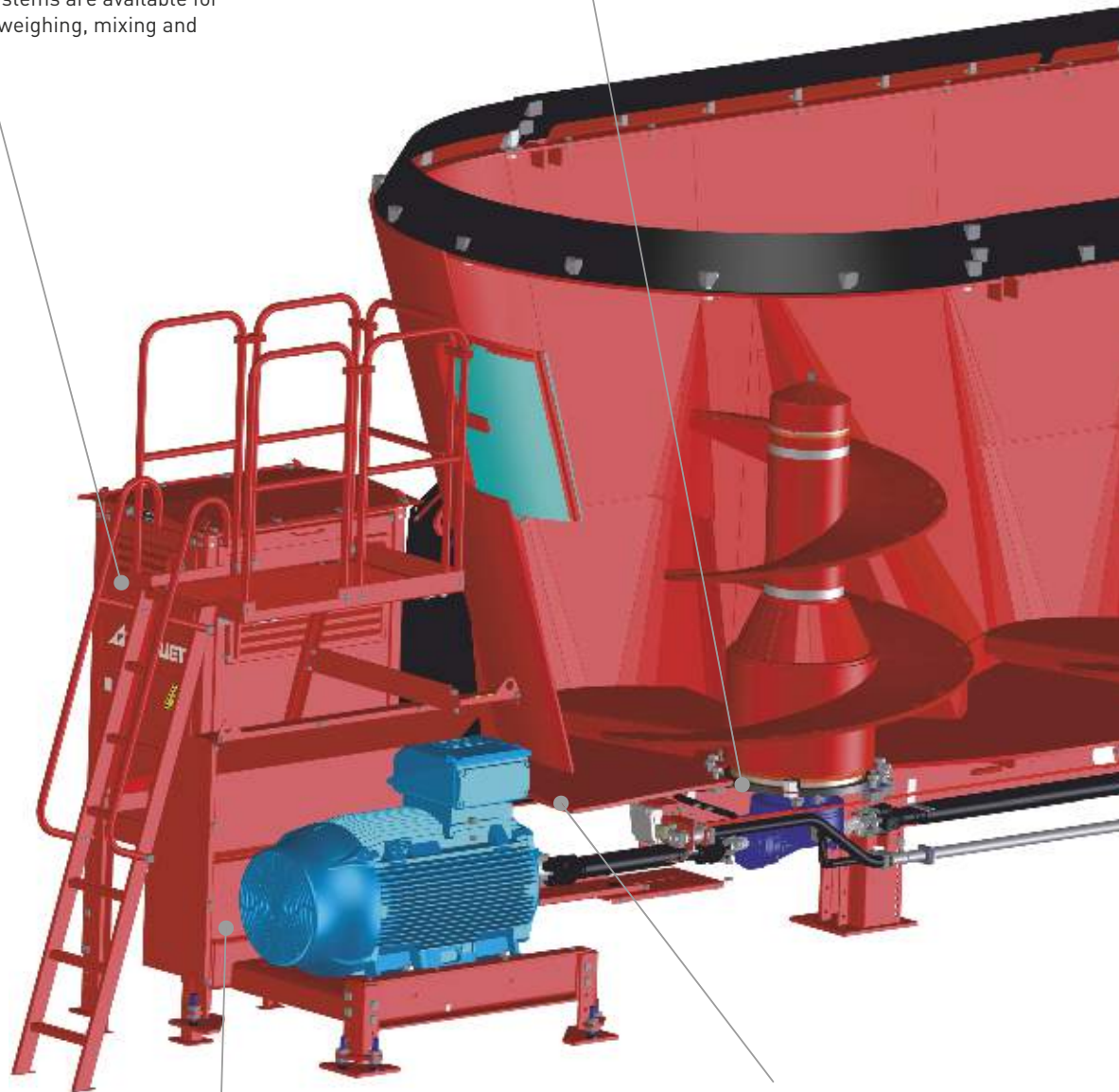

Trioliet wear ring for stability and long life time

The special Trioliet wear ring ensures a longer life of the mixing tub.



Preprogrammed frequency drive with unique software for automatic mixing speed control during mixing cycle.



Horizontal Flow by offset inserts for optimal and quick mixing in both vertical and horizontal direction (patented).

Patented Trioform auger knives

The Trioform auger knives are mounted at horizontal position on the auger flighting. This ensures an optimum cutting performance with less resistance in the feed (fuel saving). The patented Trioform auger knives are self-sharpening and the special shape lead up to a higher strength and long life.

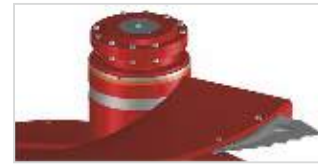

Shear bolt protection

Shear bolt protection at the top side of the auger(s). (Only for HD).

Lapped welded auger flighting

The special welding of the auger ensures a long life.

Twin Stream auger

The optimum auger shape of the Twin Stream auger result in a quick and homogeneous mixing action at a low power requirement (low power consumption). No wasted space and higher capacity of cubic foot because of slim auger body. Even and quick discharge caused by the two symmetrical dispenser arms. Twin Stream augers are manufactured out of St. 52.

Integrated chassis for long life time

All Trioliet mixer feeders have a very stable auger construction, supported on the chassis. As a result all forces on the mixing auger are directly absorbed by the chassis. The mixing tub is manufactured out of St. 52.

Unique weighing system

The Trioliet electronic weighing system comes as standard with four (4-point) heavy duty weigh bars for maximum accuracy. Every weigh bar has double sided strain gauges for maximum accuracy. The weight indicator is placed in a rugged indicator case of high-impact durable material. Many options and accessories available, like datalink wireless data transfer, feed management software, radiographic controls, remote displays and CAB control remote computers.

St. 52

All Trioliet mixer feeders (tub, auger(s), chassis and wear ring) are manufactured out of St. 52.

Heavy Duty Drive Line with heavy duty gearboxes (no reduction gearboxes)

Stationary feedings systems Solomix STAT

Models 700-2800



Features Trioliet stationary feeding systems:

- Variable speed drive for optimal mixing speed and superior discharge/clean out
- Direct drive line with one E-motor and without reduction gearbox between E-motor and planetary gearboxes
- Rotation sensors for error messaging
- One E-motor for optimum auger timing
- Adjustable in height
- High capacity chain conveyors for quick discharge
- Ideal mixers in combination with Triomatic or feed belts
- Optional cooling system for intensive use

Heavy Duty (HD) systems Solomix STAT

Models 3200-5200



8 | 9

Features Trioliet Heavy Duty feeding systems:

- Variable speed drive for optimal mixing speed and superior discharge/clean out
- High RPM Heavy Duty drive line
- Calamity protection per auger with shearbolts
- Rotation sensors for error messaging
- Direct drive line with one E-motor and without reduction gearbox between E-motor and planetary gearboxes
- One E-motor for optimum auger timing
- Adjustable in height
- High capacity chain conveyors for quick discharge in delivery trucks
- Large dairy solution
- HD cooling system for planetary drive-line



Manual control systems



Control systems

Trioliet offers 2 different control systems for controlling loading, weighing, mixing and unloading: manual control and automatic control units.

Manual control unit

The manual control unit is available for farms who don't need automation for their stationary feed mixer. The control unit can easily be installed as stand alone (plug and play) system without the need for further electrical installations. Remote controls are available for the loading and delivery vehicle. They also can operate in slave configuration, for example belt feeding systems with feeding robot.

Automatic control systems



Wireless remote control with touch screen and weight indication.

Automatic control unit

The automatic control unit is intended for farms who want to program a lot of rations. Feed ingredients, recipes, herd groups and tasks can be programmed easily into the touch screen PLC. Due to the large colour screen the farmer has a clear view of all the feed data. The mixer can be loaded by the programmed recipes automatically and eventually resize the amount of the components after the first ingredient is loaded. Discharging is also fully automated. There are remote controls with a 4,3" touch screen available for the load and delivery vehicle to operate the mixer and to make changes to the programme. The programme can communicate with the feed management programme TFM Tracker to synchronise ingredients, recipes and herd groups. The stationary mixer with this control unit is a stand-alone unit. There is no need for further electric installations. The system can work as Master and as slave.

Electronic weighing system



Triotronic 2810V

- Rugged indicator case of high-impact Lexan® durable material, water- and dust proof
- Crystal clear backlight LCD display with large figures and no sunlight reflexion
- Not programmable
- Add up or switch between weight per ingredient and Nett/Gross weight
- Timer function for programmable mixing time (for only one time)



Triotronic 3610V

- Rugged indicator case with clear backlight LCD display equal to 2810V
- Programmable weighing indicator with navigation and numeration keys
- LED light and buzzer give alarm when the target weight comes within reach
- USB connection for data communication with TFM Tracker feed management system
- Timer function for programmable mixing time

Electronic weighing system

The Trioliet electronic weighing system comes as standard with four sturdy weighcells for maximum stability. Each weighcell has two sets of strain gauges. So each weighcell measures two values and then the average is calculated. The stable, thick weighcells are not sensitive to peak loads. The gold-plated contacts ensure a high operational reliability, even under the most extreme conditions. The digital weight indicator is placed in an impact-resistant, watertight housing.



Trioliet Feed Management system for optimum feeding

TFM Tracker™ is a full-featured Windows® based feed management system. TFM Tracker™ also offers operators additional management tools including: operator control, pen review, online feed data exchange with nutritionists, ingredient tracking and numerous reports. TFM Tracker™ is an indispensable management tool for forward thinking operators! Simply enter your feed ingredients, rations, production groups, and mixer information in your TFM Tracker™ software. RF DataLink (wireless) or a USB memory device is used to transfer feeding instructions from pc to the indicator on the TFM mixer. The indicator displays the ingredients to be loaded, their weight, as well as the corresponding pen information. During feeding, the actual weights of loaded ingredients and fed ration are saved and returned via DataLink™ or USB. TFM Tracker™ software generates various detailed reports, tables and graphs, on a daily base; to control the feeding proces on your farm.

TFM Tracker

TFM Tracker™ Function	Dairy			Beef		Contractor
	LITE	PRO	PRO +	PRO	PRO +	PRO +
Communicates with EZ3610V & TST7600 Indicators	x	x	x	x	x	x
Easy to use Windows® based program	x	x	x	x	x	x
Input ingredients and track costs	x	x	x	x	x	x
Input recipes and monitor feed costs	x	x	x	x	x	x
Easy adjustment of Dry Matter values	x	x	x	x	x	x
Calculates Dry Matter Intake	x	x	x	x	x	x
Operator accuracy monitoring	Limited	x	x	x	x	x
Change "Pen Call Weight" and/or "Head Count" at indicator	x	x	x	x	x	x
Upgradable to next program level	x	x		x		
Feed refusal/weighback tracking		x	x	x	x	x
Mixer rotation counter & mix time monitoring		x	x	x	x	x
Ingredient usage report	x	x	x	x	x	x
Reports	10+	15+	25+	15+	25+	25+
Report writer offers report customization		x	x	x	x	x
Interface with most herd management programs		x	x			
Inventory monitoring & forecasting		Limited	x	Limited	x	x
Graphical reports			x		x	x
Milk production tracking		Limited	x			
Calculate income over feed costs			x		x	
Flexible workday definitions		x	x	x	x	x
Premix options		x	x	x	x	x
Automated Reports	x	x	x	x	x	x
Create recipes on a kg/load, kg/animal and percentage bases	x	x	x	x	x	x
Reports customized by pen/lot		x	x	x	x	x
Summary closeout report				x	x	
Enter cattle in and out weights				x	x	
Bunk reader module					x	
Auto adjust subsequent feeding			x		x	x
Multiple farm databases						x
Interface with the Moisture Tracker			x		x	x

Accessories



A wide range of accessories can be offered:

- Wireless remote controls for loading vehicle or delivery truck
- Triotronic electronic weighing systems 2810 V , 3610 V
- Chain conveyors, mounted to the mixer (0,91, 1,22, 2,13 or 3,35m/3, 4, 7 or 11ft.) or freestanding chain conveyors (4,27m/14ft.)
- Long Life augers with 22mm/7/8" auger flights
- Platform and Stairs
- Hay ring

Chain conveyors mounted to the mixer



Wide range of chain conveyors

We offer you chain conveyors mounted to the mixer (0,91, 1,22, 2,13 or 3,35m/3, 4, 7 or 11ft.) or freestanding chain conveyors (4,27m/14ft.)

Chain conveyors mounted to the mixer

- 0,92m/36,2" wide chain conveyor with 0,5m/19,7" high side plates
- Fixed in position
- Electrically driven by a 5HP (4kW) electric motor
- Clearance underneath 3,36m/11ft. chain conveyor from 2,35m/7,7ft. to 2,65m/8,7ft., depending on the supports height

Freestanding chain conveyors

Models Pro L and Pro XL



Pro L



Pro XL



Pro XL



Pro XL



Pro XL

Features of both Pro L and Pro XL are:

- High capacity chain conveyor to transport large amounts of feed
- Discharge clearance under the conveyor up to 4,50m/15ft. (Pro L) or 4,20m/14ft. (Pro XL)
- Self supporting frame
- Large 1,09m/43" wide conveyor with 0,43m/17" tall side walls (Pro L) or large 1,47m/58" wide conveyor with 0,81m/32" tall side walls (Pro XL)
- Electrically driven by a 5 HP/4kW electric motor (Pro L) or a 15 HP/11kW electric motor in combination with a frequency drive for smooth start-up (Pro XL)
- Two heavy roller chains result in low energy requirement for running the chain itself. Almost all driving energy can be used for feed transport.
- Glide strips for support of the slats and easy running
- Bottom plates of stainless steel
- Closed bottom underneath to protect from running parts
- Wear resistant nylon chain guidance. In this way the chain is protected from feed to guarantee a long life-time.
- The chain conveyors are, for normal rations with 50% mais, placed at an angle of 35°
For very light rations we recommend an angle of 25°

The chain conveyor is standard positioned in line with the discharge door.

Stationary

Stationary mixer feeder with one auger



Solomix 1 STAT VL

Model		700 VL	1000 VL	1200 VL	1400 VL
Discharge		1 front discharge door on the opposite side of the E-motor			
Capacity	m ³ /Cu. Ft	7/247	10/353	12/424	14/494
Overall length (excl. motor)	m/Inch	3,15/124"	3,45/136"	3,53/139"	3,70/146"
Overall length (incl. motor)	m/Inch	4,09/161"	4,26/168"	4,26/168"	4,33/170"
Overall width	m/Inch	2,15/85"	2,29/90"	2,29/91"	2,44/96"
Overall height*	m/Inch	2,08-2,38/82"-94"	2,45-2,75/97"-109"	2,65-2,95/105"-117"	2,70-3,00/107"-119"
Net weight without E-motor and frame	kg/Lbs	2,300/5.071	3,500/7.716	3,900/8.598	4,000/8.818
Number of auger knife positions		8	8	8	12
Number of knives mounted per auger		5	5	5	9
Diameter of auger Ø	m/Inch	2,00/79"	2,20/87"	2,20/87"	2,44/96"
Required electric installation		Frequency drive			

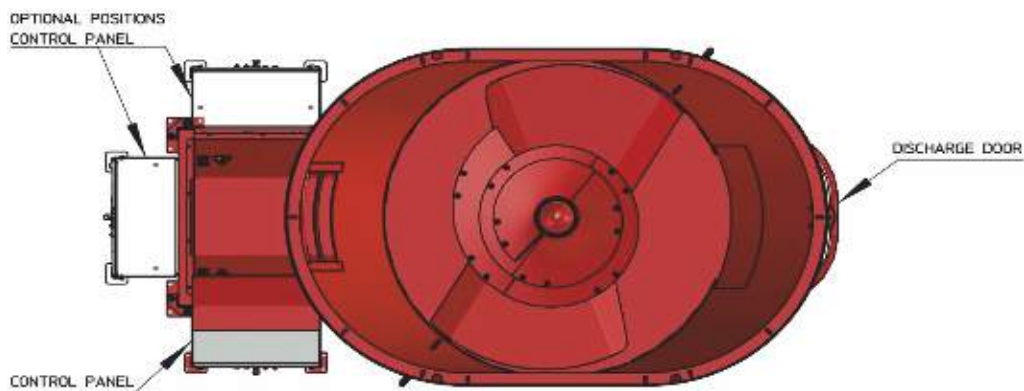

* Supports are standard adjusted on 31,5" height

Stationary



Stationary mixer feeder with one auger



Solomix 1 STAT ZK

Model	700 ZK	1000 ZK	1200 ZK	1400 ZK	
Discharge	1 side discharge door on RHS, as seen from the E-motor				
Capacity	m ³ /Cu. Ft	7/247	10/353	12/424	14/494
Overall length (excl. motor)	m/Inch	2,92/115"	3,33/131"	3,43/135"	3,71/146"
Overall length (incl. motor)	m/Inch	3,86/152"	4,11/162"	4,20/165"	4,32/170"
Overall width	m/Inch	2,21/87"	2,39/94"	2,39/94"	2,44/96"
Overall height*	m/Inch	2,09-2,39/82"-94"	2,47-2,77/97"-109"	2,67-2,98/105"-117"	2,72-3,03/107"-119"
Net weight without E-motor and frame	kg/Lbs	2,355/5.181	3,360/7.385	3,960/8.708	4,010/8.818
Number of auger knife positions		8	8	8	12
Number of knives mounted per auger		5	5	5	9
Diameter of auger Ø	m/Inch	2,00/79"	2,20/87"	2,20/87"	2,44/96"
Required electric installation	Frequency drive				

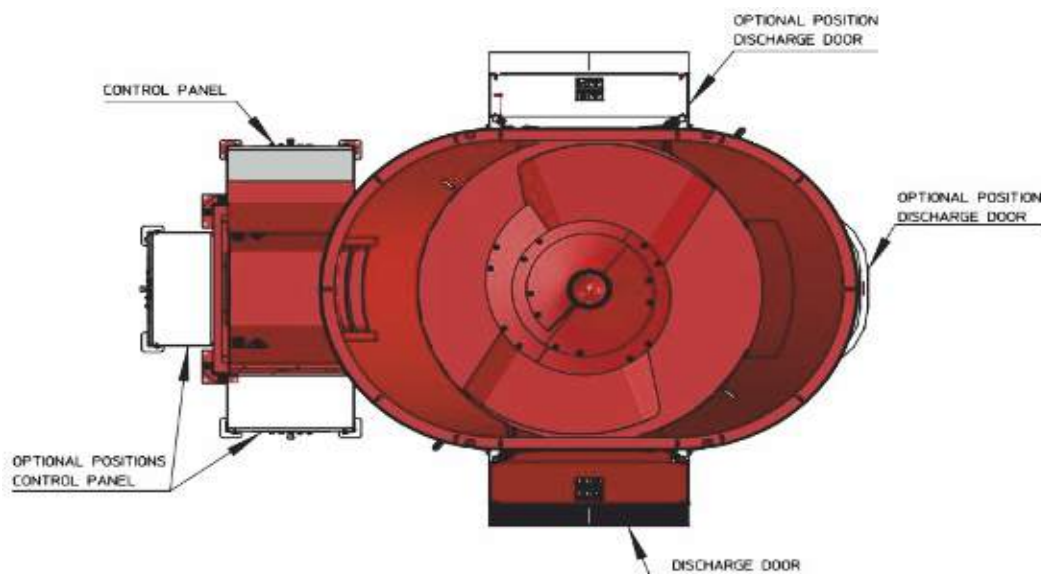

* Supports are standard adjusted on 31,5" height

Stationary

Stationary mixer feeder with two augers



Solomix 2 STAT VL

Model		1200 VL	1600 VL	2000 VL	2400 VL	2800 VL
Discharge			1 front discharge door on the opposite side of the E-motor			
Capacity	m ³ /Cu. Ft	12/424	16/565	20/706	24/848	28/1130
Overall length (excl. motor)	m/Inch	4,22/166"	4,60/181"	5,21/205"	5,72/225"	6,56/258"
Overall length (incl. motor)	m/Inch	5,24/206"	5,60/220"	6,28/247"	6,60/260"	7,40/291"
Overall width	m/Inch	2,16/85"	2,29/90"	2,44/96"	2,44/96"	2,80/110"
Overall height*	m/Inch	2,54-2,85/100"-112"	2,85-3,15/112"-124"	2,85-3,15/112"-124"	2,77-3,05/109"-120"	2,75-3,05/108"-120"
Net weight without E-motor and frame	kg/Lbs	3,410/7.496	4,760/10.472	5,415/11.905	6,415/14.109	9,420/20.723
Number of auger knife positions		7	8	10	9	12
Number of knives mounted per auger		4	5	7	6	9
Diameter of auger Ø	m/Inch	1,50/59"	1,70/67"	1,96/77"	2,20/87"	2,44/96"
Required electric installation				Frequency drive		

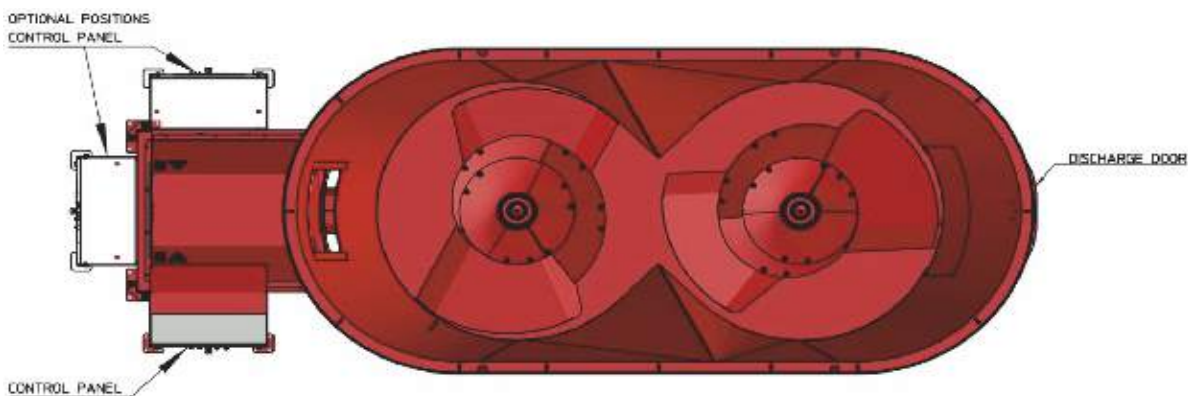

* Supports are standard adjusted on 31,5" height

** The 2800 VL and ZK are equipped with 7/8" auger flights

*** Machine for containertransport

Stationary



Stationary mixer feeder with two augers



Solomix 2 STAT ZK

Model		1200 ZK	1600 ZK	2000 ZK	2000 ZK C	2400 ZK	2800 ZK
Discharge		1 side discharge door on the right side as seen from the E-motor					
Capacity	m ³ /Cu. Ft	12/424	16/565	20/706	20/706	24/848	28/1130
Overall length (excl. motor)	m/Inch	4,55/179"	5,03/198"	5,28/208"	5,59/220"	5,72/225"	6,55/258"
Overall length (incl. motor)	m/Inch	5,57/219"	6,20/244"	6,32/249"	6,58/259"	6,60/260"	7,29/287"
Overall width	m/Inch	2,16/85"	2,32/91"	2,36/93"	2,29/90"	2,44/96"	2,80/110"
Overall height*	m/Inch	2,16-2,47/85"-97"	2,44-2,74/96"-108"	2,84-3,15/112"-124"	2,54-2,84/100"-112"	2,77-3,05/109"-120"	2,74-3,05/108"-120"
Net weight without E-motor and frame	kg/Lbs	3,710/8.157	4,510/9.921	5,210/11.464	5,510/12.125	3,030/13.779	9,120/20.062
Number of auger knife positions		7	8	8	8	9	12
Number of knives mounted per auger		4	5	5	5	6	9
Diameter of auger Ø	m/Inch	1,81/71"	1,96/77"	1,96/77"	2,20/87"	2,20/87"	2,44/96"
Required electric installation		Frequency drive					

20 | 21

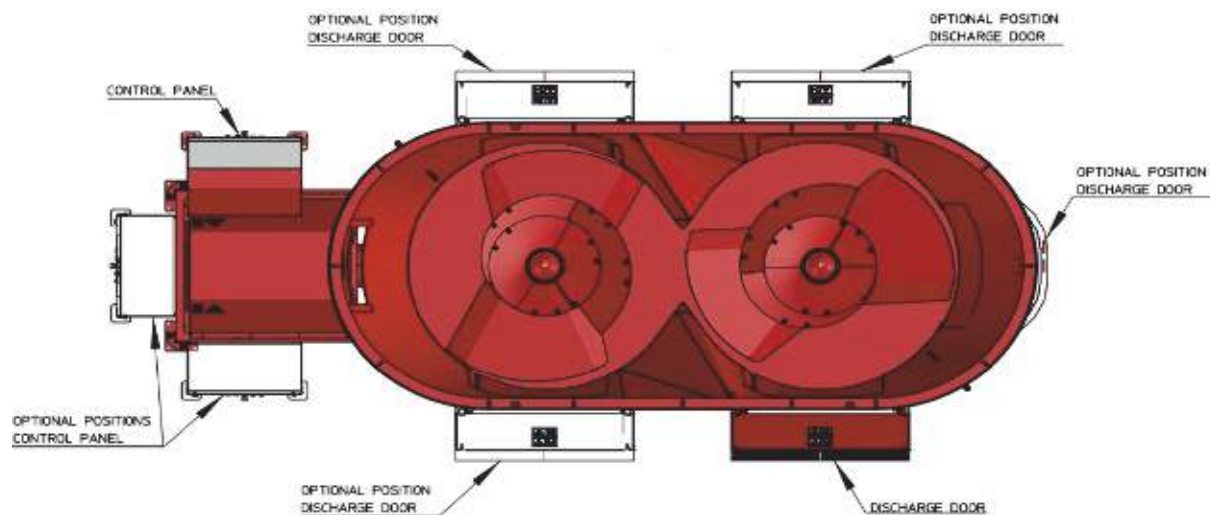

* Supports are standard adjusted on 31,5" height ** The 2800 VL and ZK are equipped with 7/8" auger flights
 *** Machine for containertransport

Stationary

Stationary mixer feeder with two or three augers



Solomix 2 en 3 STAT Heavy Duty

Model	2 3200	3 3600	3 4600	3 5200	
Discharge	1 front discharge door on the opposite side of the E-motor				
No. of mixing augers	2	3	3	3	
Capacity	m ³ /Cu. Ft	32/1150	36/1285	46/1650	52/1860
Overall length (excl. motor)	m/Inch	7,40/291"	8,81/347"	9,37/369"	10,10/398"
Overall length (incl. motor)	m/Inch	6,55/258"	7,90/311"	9,27/365"	9,30/366"
Overall width	m/Inch	2,79/110"	2,64/104"	2,97/117"	2,97/117"
Overall height*	m/Inch	2,74-3,05/108"-120"	2,85-3,15/112"-124"	2,87-3,18/113"-125"	2,90-3,20/114"-126"
Net weight without E-motor and frame	kg/Lbs	9,420/20.720	11,125/24.470	13,630/29.980	18,240/40.120
Number of auger knife positions		12	10	12	12
Number of knives mounted per auger		9	7	9	9
Diameter of auger Ø	m/Inch	2,67/105"	2,20/87"	2,44/96"	2,67/105"
Required electric installation	Frequency drive				
Standard discharge door sensor	yes	yes	yes	yes	
Standard augersensor	yes	yes	yes	yes	

* Supports are standard adjusted on 31,5" height

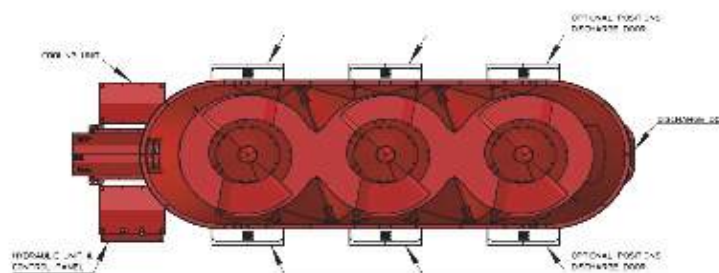
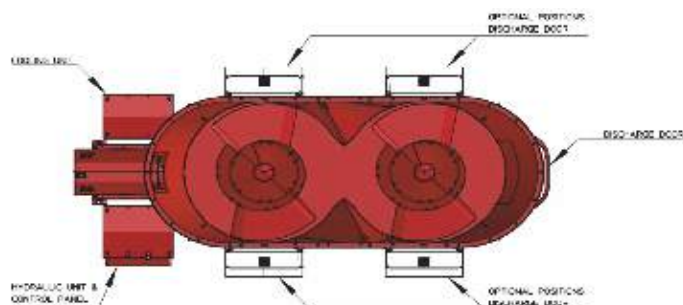

Positions of the cooling system and hydraulic unit (with control panel) could be changed.



www.trioliet.com

Trioliet BV

Kleibultweg 59
NL - 7575 BW Oldenzaal

T +31 541 - 57 21 21
F +31 541 - 57 21 25

01/17

www.trioliet.com

Trioliet. Invents for you.

